

6. If the oxide is hard to remove, and cannot be removed even by the unit. In this case, use the accessory brush to remove the oxide firstly. After that, repeat the above steps 2~5.
7. For convenient to use, the tip refresher paste can be attached on the top of unit with the two-sides tape (as the picture).

 **Caution:**

- When the tip temperature is about at 300 °C , which is the most suitable temperature for cleaning the tip.
- When the tip temperature is 400 °C or more, even if the oxide film is removed by the unit, the tip will be blackened unless it is solder promptly.
- When using the accessory brush, small scratches may be produced on the iron-plating surface of the tip. Do not always use a brush, but use only when the oxide cannot be removed by cleaning with the unit.
- Store the accessory brush in the polisher with the brush head facing down. Otherwise, personal injury may result.

## V. Clean the Tin Residue

Pull out the tin residue box from the polisher, clean the box and then place it back to the polisher.

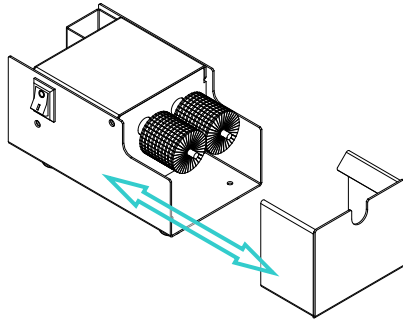

# 310 TIP CLEANER

## OPERATION MANUAL

Thank you for purchasing the tip polisher. Please read this manual before operating the unit. Store this manual in a safe, easily

accessible place for future reference.

## I. Safety Instruction

- Do not wet the unit or use the unit with wet hand.
- Take care not to pinch fingers.
- Turn the power off when not in use or left unattended.
- Removing the power cord by holding the plug-not the wires.
- Do not refit the unit.
- Turn the power off when changing parts or storing the unit. Use only the genuine replacement parts.
- While using the unit, don't do anything which may cause bodily harm or physical damage.

## II. Packing List

Main unit	1 pcs
Tip refresher paste (accessory)	1 pcs
Brush (accessory)	1 pcs

## III. Specifications

Power consumption	24VDC/12W
Speed	60R/min
Dimensions	125(D)×70(W)×65(H) mm
Weight	About 0.8 kg

※ **Note: Specifications and design are subject to change without**

**notice.**

## IV. Operation

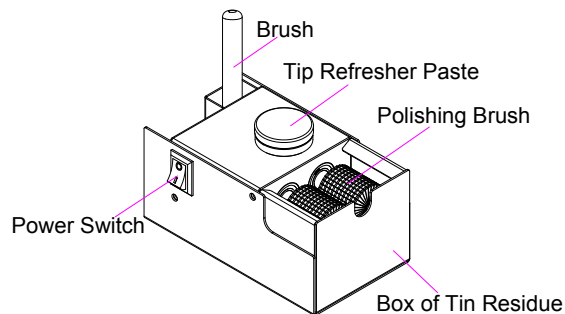

1. Turn on the power switch and the polishing brush comes to circumvolve.
2. Touch the blackened tip to the middle of the polishing brush to remove the oxide film.
3. Just after removing the oxide film of the blackened oxidized tip with the unit, please performing the tinning work again using the tip refresher paste and solder wire at once. Because the tip refresher paste is active than solder wire, it can wet the tip properly and allows better retinning.
4. Remove the solder tinning on the tip using the unit or the clean sponge.
5. After that, before normal operation, tin the tip with the solder wire currently being used in normal operation and refresh the tip.